

100-Pin TQFP  
Commercial Temp  
Industrial Temp

**512K x 18, 256K x 32, 256K x 36**  
**9Mb Sync Burst SRAMs**

5.5 ns–7.5 ns  
1.8 V or 2.5 V  $V_{DD}$   
1.8 V or 2.5 V I/O

### Features

- Flow Through operation; Pin 14 = No Connect
- 1.8 V or 2.5 V +10%/–10% core power supply
- 1.8 V or 2.5 V I/O supply
- $\overline{LBO}$  pin for Linear or Interleaved Burst mode
- Internal input resistors on mode pins allow floating mode pins
- Byte Write ( $\overline{BW}$ ) and/or Global Write ( $\overline{GW}$ ) operation
- Internal self-timed write cycle
- Automatic power-down for portable applications
- JEDEC-standard 100-lead TQFP package
- RoHS-compliant 100-lead TQFP package available

### Functional Description

#### Applications

The GS880F18/32/36BT-xxxV is a 9,437,184-bit (8,388,608-bit for x32 version) high performance synchronous SRAM with a 2-bit burst address counter. Although of a type originally developed for Level 2 Cache applications supporting high performance CPUs, the device now finds application in synchronous SRAM applications, ranging from DSP main store to networking chip set support.

#### Controls

Addresses, data I/Os, chip enables ( $\overline{E1}$ ,  $E2$ ,  $\overline{E3}$ ), address burst control inputs ( $\overline{ADSP}$ ,  $\overline{ADSC}$ ,  $\overline{ADV}$ ), and write control inputs ( $\overline{Bx}$ ,  $\overline{BW}$ ,  $\overline{GW}$ ) are synchronous and are controlled by a positive-edge-triggered clock input (CK). Output enable ( $\overline{G}$ ) and power down control (ZZ) are asynchronous inputs. Burst cycles can be initiated with either  $\overline{ADSP}$  or  $\overline{ADSC}$  inputs. In Burst mode, subsequent burst addresses are generated internally and are controlled by  $\overline{ADV}$ . The burst address counter may be configured to count in either linear or interleave order with the Linear Burst Order ( $\overline{LBO}$ ) input. The Burst function need not be used. New addresses can be loaded on every cycle with no degradation of chip performance.

### Designing For Compatibility

The JEDEC standard for Burst RAMS calls for a  $\overline{FT}$  mode pin option on Pin 14. Board sites for flow through Burst RAMS should be designed with  $V_{SS}$  connected to the  $\overline{FT}$  pin location to ensure the broadest access to multiple vendor sources. Boards designed with  $\overline{FT}$  pin pads tied to  $V_{SS}$  may be stuffed with GSI's pipeline/flow through-configurable Burst RAMs or any vendor's flow through or configurable Burst SRAM. Boards designed with the  $\overline{FT}$  pin location tied high or floating must employ a non-configurable flow through Burst RAM, like this RAM, to achieve flow through functionality.

### Byte Write and Global Write

Byte write operation is performed by using Byte Write enable ( $\overline{BW}$ ) input combined with one or more individual byte write signals ( $\overline{Bx}$ ). In addition, Global Write ( $\overline{GW}$ ) is available for writing all bytes at one time, regardless of the Byte Write control inputs.

### Sleep Mode

Low power (Sleep mode) is attained through the assertion (High) of the ZZ signal, or by stopping the clock (CK). Memory data is retained during Sleep mode.

### Core and Interface Voltages

The GS880F18/32/36BT-xxxV operates on a 1.8 V or 2.5 V power supply. All input are 2.5 V and 1.8 V compatible. Separate output power ( $V_{DDQ}$ ) pins are used to decouple output noise from the internal circuits and are 2.5 V and 1.8 V compatible.

### Parameter Synopsis

		-5.5	-6.5	-150	Unit
Flow Through 2-1-1-1	$t_{kQ}$	5.5	6.5	7.5	ns
	tCycle	5.5	6.5	7.5	ns
	Curr (x18)	160	140	128	mA
	Curr (x32/x36)	185	160	145	mA



GS880F32BT-xxxV 100-Pin TQFP Pinout (Package T)

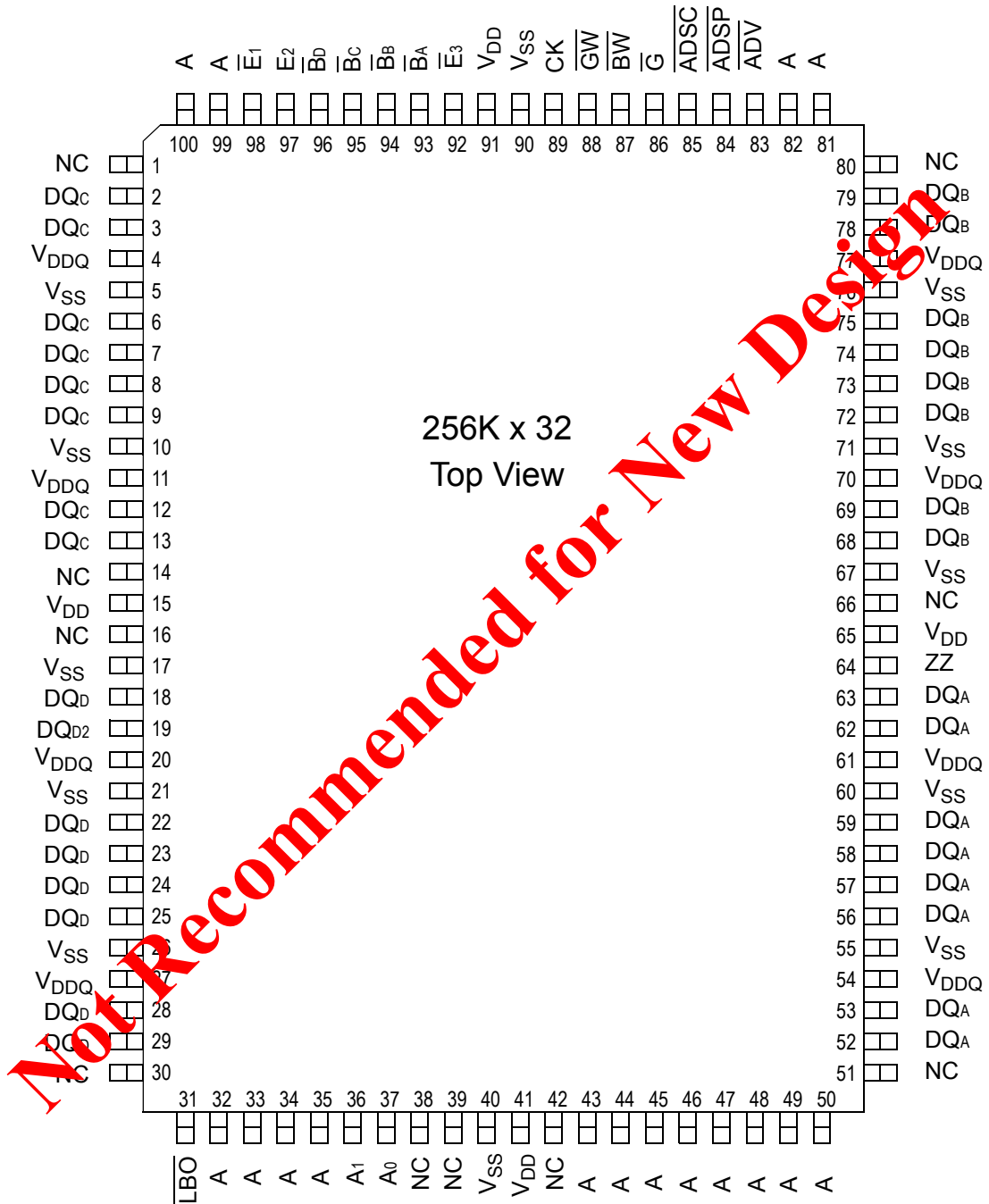

**Note:**

Pins marked with NC can be tied to either VDD or VSS. These pins can also be left floating.

GS880F36BT-xxxV 100-Pin TQFP Pinout (Package T)

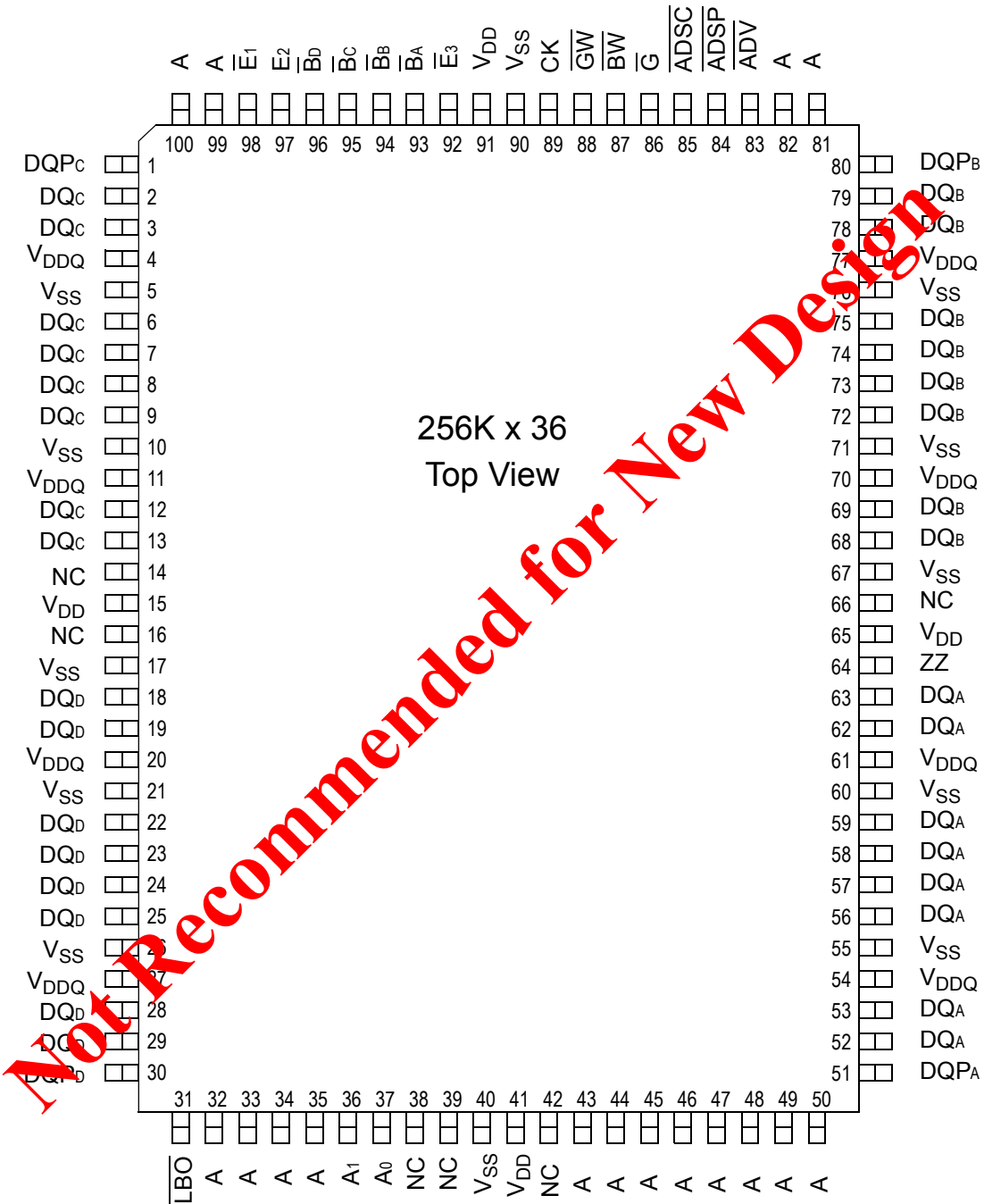

**Note:**  
Pins marked with NC can be tied to either VDD or VSS. These pins can also be left floating.

**TQFP Pin Description**

Symbol	Type	Description
A <sub>0</sub> , A <sub>1</sub>	I	Address field LSBs and Address Counter preset Inputs
A	I	Address Inputs
DQ <sub>A</sub> DQ <sub>B</sub> DQ <sub>C</sub> DQ <sub>D</sub>	I/O	Data Input and Output pins
NC	—	No Connect
$\overline{BW}$	I	Byte Write—Writes all enabled bytes; active low
B <sub>A</sub> , B <sub>B</sub> , B <sub>C</sub> , B <sub>D</sub>	I	Byte Write Enable for DQ <sub>A</sub> , DQ <sub>B</sub> Data I/Os; active low
CK	I	Clock Input Signal; active high
$\overline{GW}$	I	Global Write Enable—Writes all bytes; active low
$\overline{E_1}$ , E <sub>3</sub>	I	Chip Enable; active low
E <sub>2</sub>	I	Chip Enable; active high
$\overline{G}$	I	Output Enable; active low
$\overline{ADV}$	I	Burst address counter advance enable; active low
$\overline{ADSP}$ , $\overline{ADSC}$	I	Address Strobe (Processor, Cache Controller); active low
$\overline{ZZ}$	I	Sleep Mode control; active high
$\overline{LBO}$	I	Linear Burst Order mode; active low
V <sub>DD</sub>	I	Core power supply
V <sub>SS</sub>	I	I/O and Core Ground
V <sub>DDQ</sub>	I	Output driver power supply

Not Recommended for New Design

GS880F18/32/36BT-xxxV Block Diagram

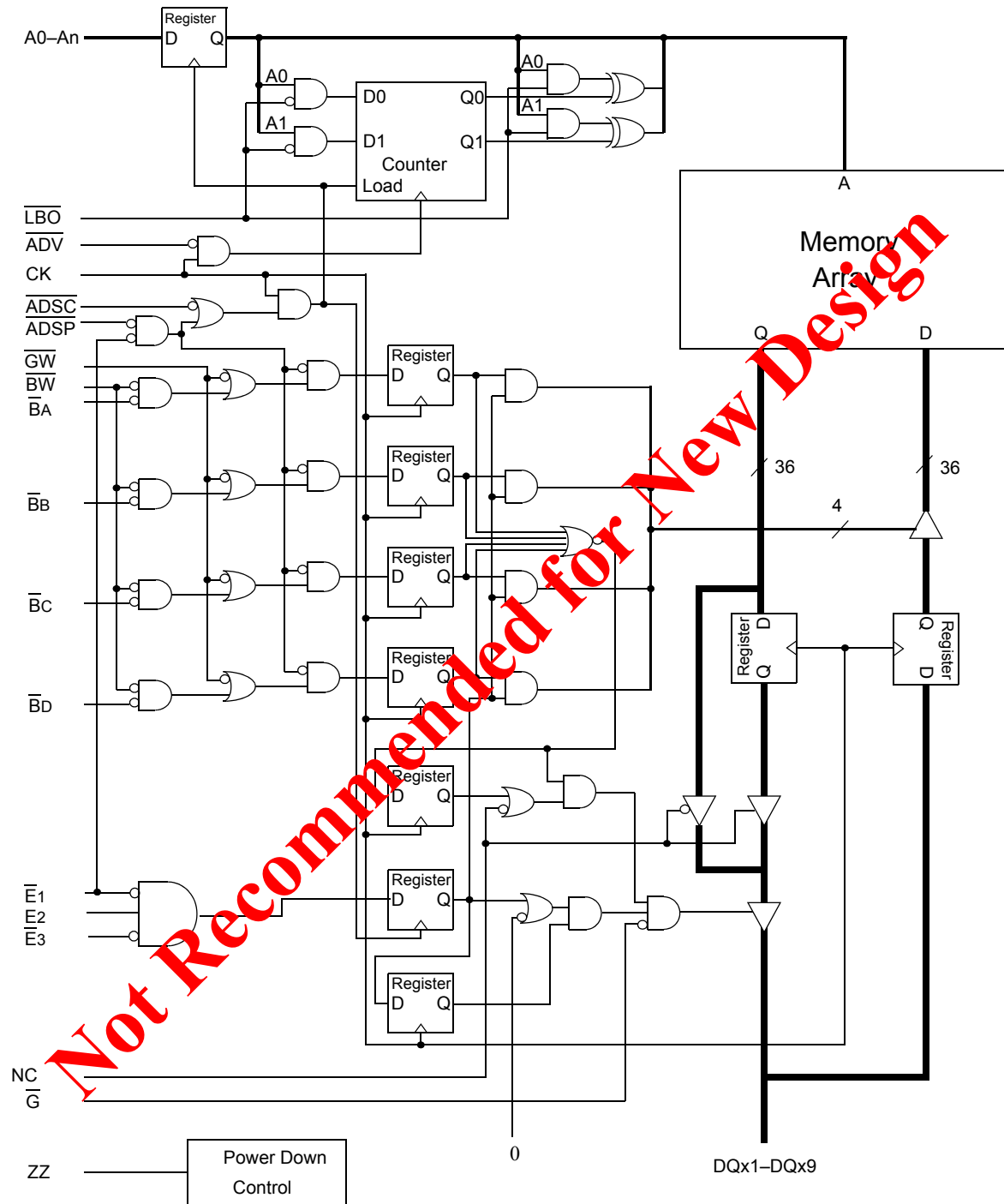

Note: Only x36 version shown for simplicity.

**Byte Write Truth Table**

Function	$\overline{GW}$	$\overline{BW}$	$\overline{BA}$	$\overline{BB}$	$\overline{BC}$	$\overline{BD}$	Notes
Read	H	H	X	X	X	X	1
Write No Bytes	H	L	H	H	H	H	1
Write byte a	H	L	L	H	H	H	2, 3
Write byte b	H	L	H	L	H	H	2, 3
Write byte c	H	L	H	H	L	H	2, 3, 4
Write byte d	H	L	H	H	H	L	2, 3, 4
Write all bytes	H	L	L	L	L	L	2, 3, 4
Write all bytes	L	X	X	X	X	X	

**Notes:**

1. All byte outputs are active in read cycles regardless of the state of Byte Write Enable inputs,  $\overline{BA}$ ,  $\overline{BB}$ ,  $\overline{BC}$  and/or  $\overline{BD}$ .
2. Byte Write Enable inputs  $\overline{BA}$ ,  $\overline{BB}$ ,  $\overline{BC}$  and/or  $\overline{BD}$  may be used in any combination with  $\overline{BW}$  to write single or multiple bytes.
3. All byte I/Os remain High-Z during all write operations regardless of the state of Byte Write Enable inputs.
4. Bytes "C" and "D" are only available on the x32 and x36 versions.

Not Recommended for New Design

## Synchronous Truth Table

Operation	Address Used	State Diagram Key	$\bar{E}_1$	$E_2$	$\bar{E}_3$	$\overline{ADSP}$	$\overline{ADSC}$	$\overline{ADV}$	$\bar{W}$	DQ <sup>3</sup>
Deselect Cycle, Power Down	None	X	L	X	H	X	L	X	X	High-Z
Deselect Cycle, Power Down	None	X	L	L	X	X	L	X	X	High-Z
Deselect Cycle, Power Down	None	X	L	X	H	L	X	X	X	High-Z
Deselect Cycle, Power Down	None	X	L	L	X	L	X	X	X	High-Z
Deselect Cycle, Power Down	None	X	H	X	X	X	L	X	X	High-Z
Read Cycle, Begin Burst	External	R	L	H	L	L	X	X	X	Q
Read Cycle, Begin Burst	External	R	L	H	L	H	L	X	F	Q
Write Cycle, Begin Burst	External	W	L	H	L	H	L	X	T	D
<i>Read Cycle, Continue Burst</i>	<i>Next</i>	<i>CR</i>	X	X	X	H	H	L	F	Q
Read Cycle, Continue Burst	Next	CR	H	X	X	X	H	L	F	Q
<i>Write Cycle, Continue Burst</i>	<i>Next</i>	<i>CW</i>	X	X	X	H	H	L	T	D
Write Cycle, Continue Burst	Next	CW	H	X	X	X	H	L	T	D
Read Cycle, Suspend Burst	Current		X	X	X	H	H	H	F	Q
Read Cycle, Suspend Burst	Current		H	X	X	X	H	H	F	Q
Write Cycle, Suspend Burst	Current		X	X	X	H	H	H	T	D
Write Cycle, Suspend Burst	Current		H	X	X	X	H	H	T	D

## Notes:

- X = Don't Care, H = High, L = Low
- $E = T$  (True) if  $E_2 = 1$  and  $\bar{E}_1 = \bar{E}_3 = 0$ ,  $E = F$  (False) if  $E_2 = 0$  or  $\bar{E}_1 = 1$  or  $\bar{E}_3 = 1$
- $\bar{W} = T$  (True) and F (False) is defined in the Byte Write Truth Table preceding.
- $\bar{G}$  is an asynchronous input.  $\bar{G}$  can be driven high at any time to disable active output drivers.  $\bar{G}$  low can only enable active drivers (shown as "Q" in the Truth Table above).
- All input combinations shown above are tested and supported. Input combinations shown in gray boxes need not be used to accomplish basic synchronous or asynchronous burst operations and may be avoided for simplicity.
- Tying  $\overline{ADSP}$  high and  $\overline{ADSC}$  low allows simple non-burst synchronous operations. See **BOLD** items above.
- Tying  $\overline{ADSP}$  high and  $\overline{ADV}$  low while using  $\overline{ADSC}$  to load new addresses allows simple burst operations. See *ITALIC* items above.

Simplified State Diagram

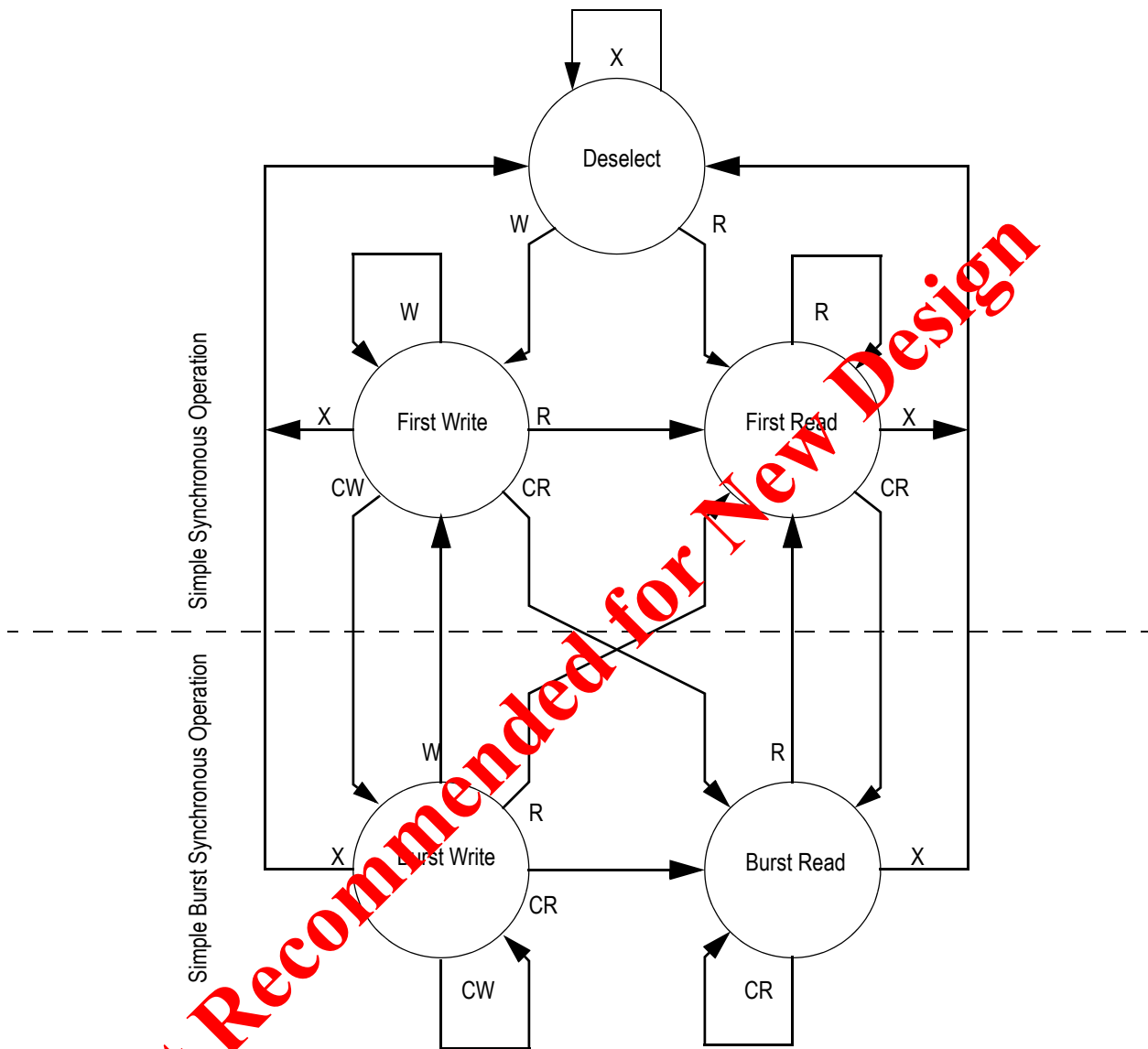

Notes:

1. The diagram shows only supported (tested) synchronous state transitions. The diagram presumes  $\overline{G}$  is tied low.
2. The upper portion of the diagram assumes active use of only the Enable ( $\overline{E1}$ ,  $E2$ , and  $E3$ ) and Write ( $\overline{BA}$ ,  $\overline{BB}$ ,  $\overline{BC}$ ,  $\overline{BD}$ ,  $\overline{BW}$ , and  $\overline{GW}$ ) control inputs, and that  $\overline{ADSP}$  is tied high and  $\overline{ADSC}$  is tied low.
3. The upper and lower portions of the diagram together assume active use of only the Enable, Write, and  $\overline{ADSC}$  control inputs, and assumes  $\overline{ADSP}$  is tied high and  $\overline{ADV}$  is tied low.

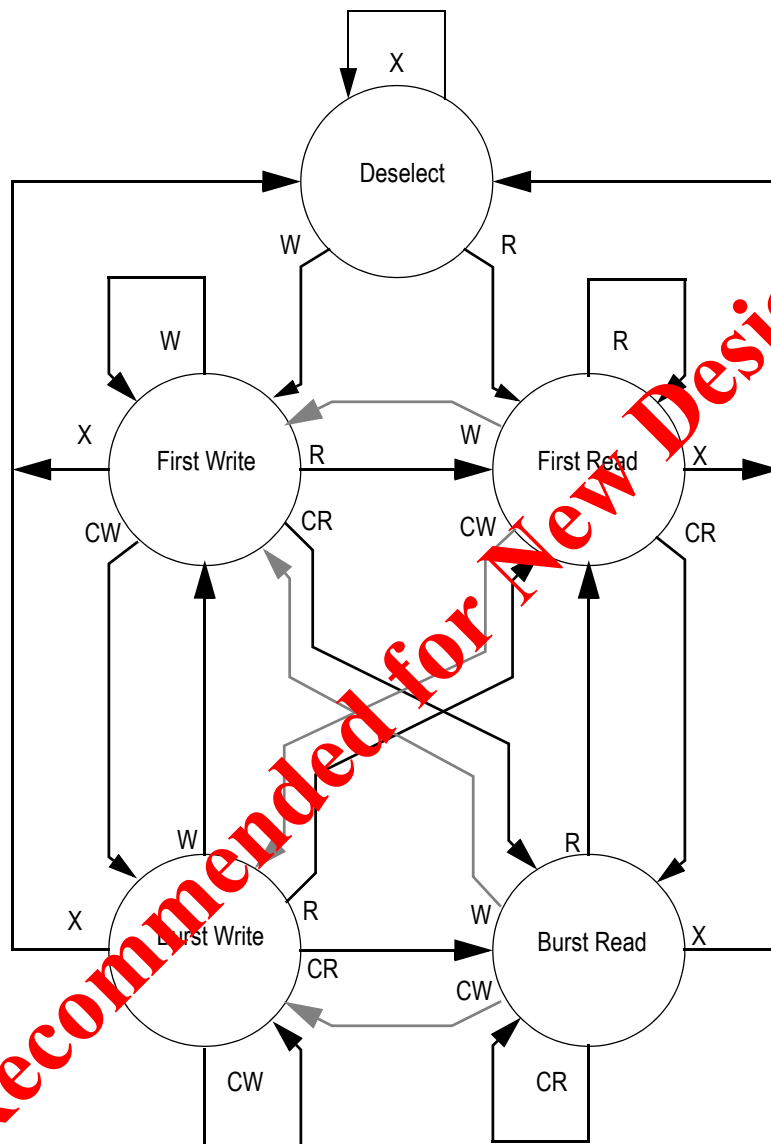
Simplified State Diagram with  $\overline{G}$ 

**Notes:**

1. The diagram shows supported (tested) synchronous state transitions plus supported transitions that depend upon the use of  $\overline{G}$ .
2. Use of "Dummy Reads" (Read Cycles with  $\overline{G}$  High) may be used to make the transition from Read cycles to Write cycles without passing through a Deselect cycle. Dummy Read cycles increment the address counter just like normal read cycles.
3. Transitions shown in gray tone assume  $\overline{G}$  has been pulsed high long enough to turn the RAM's drivers off and for incoming data to meet Data Input Set Up Time.

**Absolute Maximum Ratings**

 (All voltages reference to  $V_{SS}$ )

Symbol	Description	Value	Unit
$V_{DD}$	Voltage on $V_{DD}$ Pins	-0.5 to 4.6	V
$V_{DDQ}$	Voltage on $V_{DDQ}$ Pins	-0.5 to $V_{DD}$	V
$V_{I/O}$	Voltage on I/O Pins	-0.5 to $V_{DDQ} + 0.5$ ( $\leq 4.6$ V max.)	V
$V_{IN}$	Voltage on Other Input Pins	-0.5 to $V_{DD} + 0.5$ ( $\leq 4.6$ V max.)	V
$I_{IN}$	Input Current on Any Pin	+/-20	mA
$I_{OUT}$	Output Current on Any I/O Pin	+/-20	mA
$P_D$	Package Power Dissipation	1.5	W
$T_{STG}$	Storage Temperature	-55 to 125	$^{\circ}C$
$T_{BIAS}$	Temperature Under Bias	-55 to 125	$^{\circ}C$

**Note:**

Permanent damage to the device may occur if the Absolute Maximum Ratings are exceeded. Operation should be restricted to Recommended Operating Conditions. Exposure to conditions exceeding the Absolute Maximum Ratings, for an extended period of time, may affect reliability of this component.

**Power Supply Voltage Ranges (1.8 V/2.5 V Version)**

Parameter	Symbol	Min.	Typ.	Max.	Unit	Notes
1.8 V Supply Voltage	$V_{DD1}$	1.7	1.8	2.0	V	
2.5 V Supply Voltage	$V_{DD2}$	2.3	2.5	2.7	V	
1.8 V $V_{DDQ}$ I/O Supply Voltage	$V_{DDQ1}$	1.7	1.8	$V_{DD}$	V	
2.5 V $V_{DDQ}$ I/O Supply Voltage	$V_{DDQ2}$	2.3	2.5	$V_{DD}$	V	

**Notes:**

- The part numbers of Industrial Temperature Range versions end the character "I". Unless otherwise noted, all performance specifications quoted are evaluated for worst case in the temperature range marked on the device.
- Input Under/overshoot voltage must be  $-2\text{ V} > V_i < V_{DDn} + 2\text{ V}$  not to exceed 4.6 V maximum, with a pulse width not to exceed 20% tKC.

**$V_{DDQ2}$  &  $V_{DDQ1}$  Range Logic Levels**

Parameter	Symbol	Min.	Typ.	Max.	Unit	Notes
$V_{DD}$ Input High Voltage	$V_{IH}$	$0.6 \cdot V_{DD}$	—	$V_{DD} + 0.3$	V	1
$V_{DD}$ Input Low Voltage	$V_{IL}$	-0.3	—	$0.3 \cdot V_{DD}$	V	1

**Notes:**

- The part numbers of Industrial Temperature Range versions end the character "I". Unless otherwise noted, all performance specifications quoted are evaluated for worst case in the temperature range marked on the device.
- Input Under/overshoot voltage must be  $-2\text{ V} > V_i < V_{DDn} + 2\text{ V}$  not to exceed 4.6 V maximum, with a pulse width not to exceed 20% tKC.

**Recommended Operating Temperatures**

Parameter	Symbol	Min.	Typ.	Max.	Unit	Notes
Ambient Temperature (Commercial Range Versions)	$T_A$	0	25	70	$^{\circ}\text{C}$	2
Ambient Temperature (Industrial Range Versions)	$T_A$	-40	25	85	$^{\circ}\text{C}$	2

**Notes:**

- The part numbers of Industrial Temperature Range versions end the character "I". Unless otherwise noted, all performance specifications quoted are evaluated for worst case in the temperature range marked on the device.
- Input Under/overshoot voltage must be  $-2\text{ V} > V_i < V_{DDn} + 2\text{ V}$  not to exceed 4.6 V maximum, with a pulse width not to exceed 20% tKC.

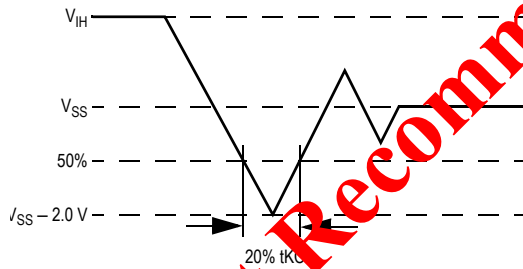
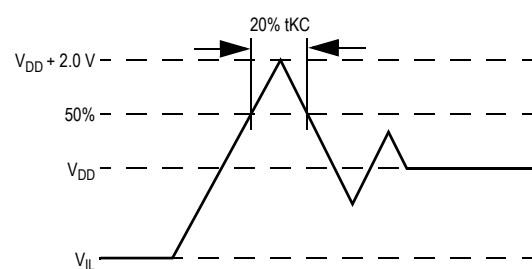
**Undershoot Measurement and Timing**

**Overshoot Measurement and Timing**

**Capacitance**

( $T_A = 25^{\circ}\text{C}$ ,  $f = 1\text{ MHz}$ ,  $V_{DD} = 2.5\text{ V}$ )

Parameter	Symbol	Test conditions	Typ.	Max.	Unit
Input Capacitance	$C_{IN}$	$V_{IN} = 0\text{ V}$	8	10	pF
Input/Output Capacitance	$C_{I/O}$	$V_{OUT} = 0\text{ V}$	12	14	pF

**Note:**

These parameters are sample tested.

### AC Test Conditions

Parameter	Conditions
Input high level	$V_{DD} - 0.2\text{ V}$
Input low level	0.2 V
Input slew rate	1 V/ns
Input reference level	$V_{DD}/2$
Output reference level	$V_{DDQ}/2$
Output load	<b>Fig. 1</b>

#### Notes:

1. Include scope and jig capacitance.
2. Test conditions as specified with output loading as shown in **Fig. 1** unless otherwise noted.
3. Device is deselected as defined by the Truth Table.

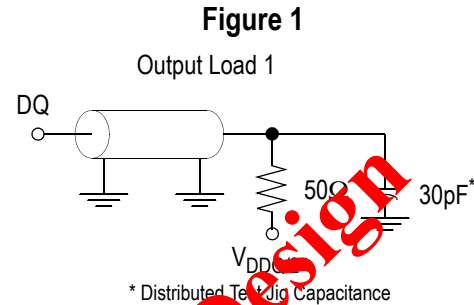

### DC Electrical Characteristics

Parameter	Symbol	Test Conditions	Min	Max
Input Leakage Current (except mode pins)	$I_{IL}$	$V_{IN} = 0\text{ to }V_{DD}$	-1 $\mu\text{A}$	1 $\mu\text{A}$
$\overline{FT}$ , ZZ Input Current	$I_{IN}$	$V_{DD} \geq V_{IN} \geq 0\text{ V}$	-100 $\mu\text{A}$	100 $\mu\text{A}$
Output Leakage Current	$I_{OL}$	Output Disable, $V_{OUT} = 0\text{ to }V_{DD}$	-1 $\mu\text{A}$	1 $\mu\text{A}$

### DC Output Characteristics (1.8 V/2.5 V Version)

Parameter	Symbol	Test Conditions	Min	Max
1.8 V Output High Voltage	$V_{OH1}$	$I_{OH} = -4\text{ mA}$ , $V_{DDQ} = 1.7\text{ V}$	$V_{DDQ} - 0.4\text{ V}$	—
2.5 V Output High Voltage	$V_{OH2}$	$I_{OH} = -8\text{ mA}$ , $V_{DDQ} = 2.375\text{ V}$	1.7 V	—
1.8 V Output Low Voltage	$V_{OL1}$	$I_{OL} = 4\text{ mA}$	—	0.4 V
2.5 V Output Low Voltage	$V_{OL2}$	$I_{OL} = 8\text{ mA}$	—	0.4 V

**Operating Currents**

Parameter	Test Conditions	Mode		Symbol	-5.5		-6.5		-7.5		Unit
					0 to 70°C	-40 to 85°C	0 to 70°C	-40 to 85°C	0 to 70°C	-40 to 85°C	
Operating Current	Device Selected; All other inputs $\geq V_{IH}$ or $\leq V_{IL}$ Output open	(x32/x36)	Flow Through	$I_{DD}$ $I_{DDQ}$	160 25	180 25	140 20	160 20	130 15	150 15	mA
		(x18)	Flow Through	$I_{DD}$ $I_{DDQ}$	145 15	165 15	130 10	150 10	120 8	140 8	mA
Standby Current	$ZZ \geq V_{DD} - 0.2 V$	Flow Through		$I_{SB}$	40	50	40	50	40	50	mA
Deselect Current	Device Deselected; All other inputs $\geq V_{IH}$ or $\leq V_{IL}$	Flow Through		$I_{DD}$	60	65	55	55	50	55	mA

**Notes:**

- $I_{DD}$  and  $I_{DDQ}$  apply to any combination of  $V_{DD2}$ ,  $V_{DD1}$ ,  $V_{DDQ2}$ , and  $V_{DDQ1}$  operation.
- All parameters listed are worst case scenario.

**AC Electrical Characteristics**

Parameter	Symbol	-5.5		-6.5		-7.5		Unit	
		Min	Max	Min	Max	Min	Max		
Flow Through	Clock Cycle Time	$t_{KC}$	5.5	—	6.5	—	7.5	—	ns
	Clock to Output Valid	$t_{COV}$	—	5.5	—	6.5	—	7.5	ns
	Clock to Output Invalid	$t_{COX}$	2.0	—	2.0	—	2.0	—	ns
	Clock to Output in Low-Z	$t_{LZ}^1$	2.0	—	2.0	—	2.0	—	ns
	Setup time	$t_S$	1.5	—	1.5	—	1.5	—	ns
	Hold time	$t_H$	0.5	—	0.5	—	0.5	—	ns
	Clock HIGH Time	$t_{KH}$	1.3	—	1.3	—	1.5	—	ns
	Clock LOW Time	$t_{KL}$	1.7	—	1.7	—	1.7	—	ns
	Clock to Output in High-Z	$t_{HZ}^1$	1.5	2.5	1.5	3.0	1.5	3.0	ns
	$\bar{G}$ to Output Valid	$t_{OE}$	—	2.5	—	3.0	—	3.8	ns
	$\bar{G}$ to output in Low-Z	$t_{OLZ}^1$	0	—	0	—	0	—	ns
	$\bar{G}$ to output in High-Z	$t_{OHZ}^1$	—	2.5	—	3.0	—	3.8	ns
	ZZ setup time	$t_{ZZS}^2$	5	—	5	—	5	—	ns
	ZZ hold time	$t_{ZZH}^2$	1	—	1	—	1	—	ns
ZZ recovery	$t_{ZZR}$	20	—	20	—	20	—	ns	

**Notes:**

- These parameters are sampled and are not 100% tested.
- ZZ is an asynchronous signal. However, in order to be recognized on any given clock cycle, ZZ must meet the specified setup and hold times as specified above.

### Flow Through Mode Timing

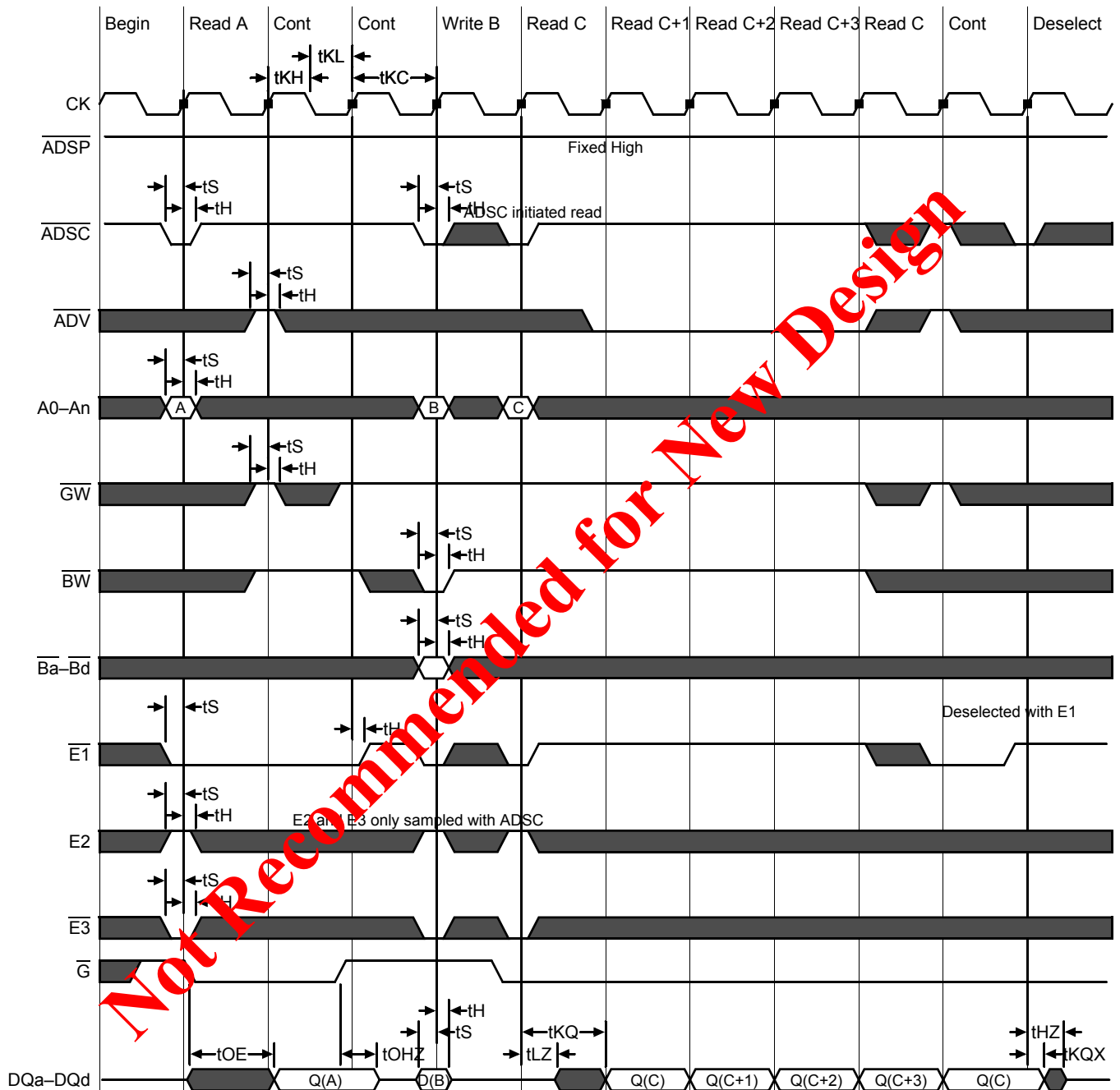

Not Recommended for New Design

### Sleep Mode

During normal operation, ZZ must be pulled low, either by the user or by its internal pull down resistor. When ZZ is pulled high, the SRAM will enter a Power Sleep mode after 2 cycles. At this time, internal state of the SRAM is preserved. When ZZ returns to low, the SRAM operates normally after ZZ recovery time.

Sleep mode is a low current, power-down mode in which the device is deselected and current is reduced to  $I_{SB2}$ . The duration of Sleep mode is dictated by the length of time the ZZ is in a High state. After entering Sleep mode, all inputs except ZZ become disabled and all outputs go to High-Z. The ZZ pin is an asynchronous, active high input that causes the device to enter Sleep mode. When the ZZ pin is driven high,  $I_{SB2}$  is guaranteed after the time  $t_{ZZI}$  is met. Because ZZ is an asynchronous input, pending operations or operations in progress may not be properly completed if ZZ is asserted. Therefore, Sleep mode must not be initiated until valid pending operations are completed. Similarly, when exiting Sleep mode during  $t_{ZZR}$ , only a De-select or Read commands may be applied while the SRAM is recovering from Sleep mode.

Sleep Mode Timing Diagram

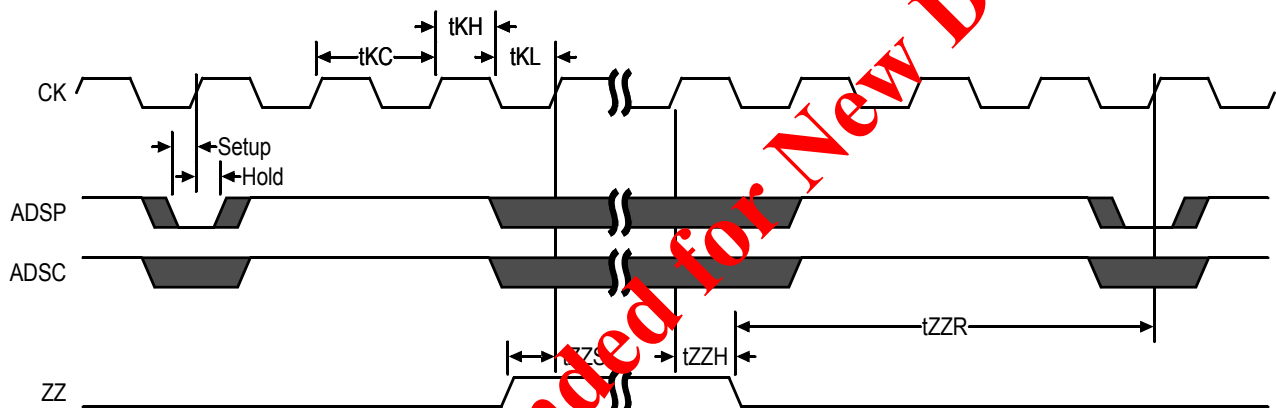

Not Recommended for New Design

## TQFP Package Drawing (Package T)

Symbol	Description	Min.	Nom.	Max
A1	Standoff	0.05	0.10	0.15
A2	Body Thickness	1.35	1.40	1.45
b	Lead Width	0.20	0.30	0.40
c	Lead Thickness	0.09	—	0.20
D	Terminal Dimension	21.9	22.0	22.1
D1	Package Body	19.9	20.0	20.1
E	Terminal Dimension	15.9	16.0	16.1
E1	Package Body	13.9	14.0	14.1
e	Lead Pitch	—	0.65	—
L	Foot Length	0.45	0.60	0.75
L1	Lead Length	—	1.00	—
Y	Coplanarity			0.10
$\theta$	Lead Angle	0°	—	7°

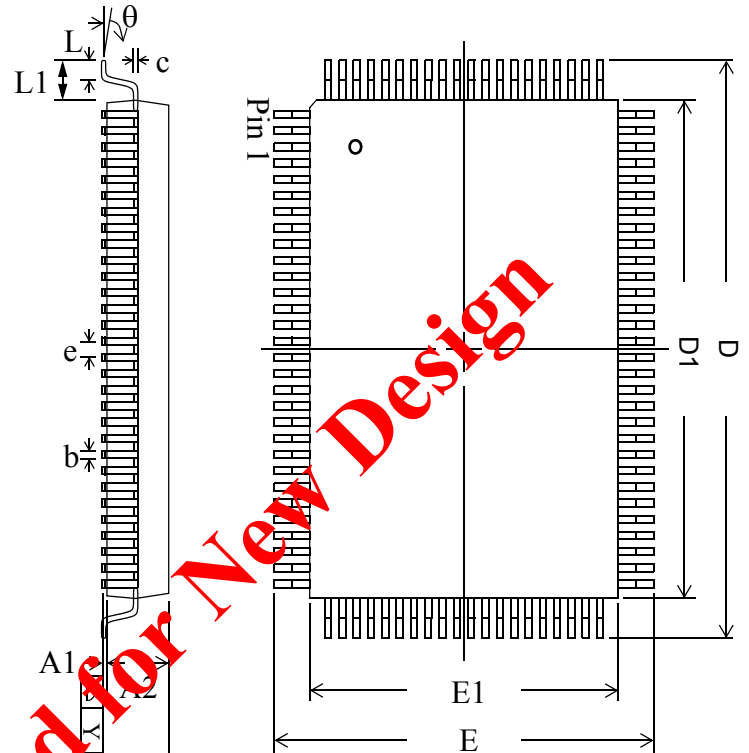
**Notes:**

1. All dimensions are in millimeters (mm).
2. Package width and length do not include mold protrusion.

Not Recommended for New Design

**Ordering Information for GSI Synchronous Burst RAMs**

Org	Part Number <sup>1</sup>	Type	Voltage Option	Package	Speed <sup>2</sup> (ns)	T <sub>A</sub> <sup>3</sup>	Status <sup>4</sup>
512K x 18	GS880F18BT-5.5V	Flow Through	1.8 V or 2.5 V	TQFP	5.5	C	MP
512K x 18	GS880F18BT-6.5V	Flow Through	1.8 V or 2.5 V	TQFP	6.5	C	MP
512K x 18	GS880F18BT-7.5V	Flow Through	1.8 V or 2.5 V	TQFP	7.5	C	MP
256K x 32	GS880F32BT-5.5V	Flow Through	1.8 V or 2.5 V	TQFP	5.5	C	MP
256K x 32	GS880F32BT-6.5V	Flow Through	1.8 V or 2.5 V	TQFP	6.5	C	MP
256K x 32	GS880F32BT-7.5V	Flow Through	1.8 V or 2.5 V	TQFP	7.5	C	MP
256K x 36	GS880F36BT-5.5V	Flow Through	1.8 V or 2.5 V	TQFP	5.5	C	MP
256K x 36	GS880F36BT-6.5V	Flow Through	1.8 V or 2.5 V	TQFP	6.5	C	MP
256K x 36	GS880F36BT-7.5V	Flow Through	1.8 V or 2.5 V	TQFP	7.5	C	MP
512K x 18	GS880F18BT-5.5IV	Flow Through	1.8 V or 2.5 V	TQFP	5.5	I	MP
512K x 18	GS880F18BT-6.5IV	Flow Through	1.8 V or 2.5 V	TQFP	6.5	I	MP
512K x 18	GS880F18BT-7.5IV	Flow Through	1.8 V or 2.5 V	TQFP	7.5	I	MP
256K x 32	GS880F32BT-5.5IV	Flow Through	1.8 V or 2.5 V	TQFP	5.5	I	MP
256K x 32	GS880F32BT-6.5IV	Flow Through	1.8 V or 2.5 V	TQFP	6.5	I	MP
256K x 32	GS880F32BT-7.5IV	Flow Through	1.8 V or 2.5 V	TQFP	7.5	I	MP
256K x 36	GS880F36BT-5.5IV	Flow Through	1.8 V or 2.5 V	TQFP	5.5	I	MP
256K x 36	GS880F36BT-6.5IV	Flow Through	1.8 V or 2.5 V	TQFP	6.5	I	MP
256K x 36	GS880F36BT-7.5IV	Flow Through	1.8 V or 2.5 V	TQFP	7.5	I	MP
512K x 18	GS880F18BGT-5.5V	Flow Through	1.8 V or 2.5 V	RoHS-compliant TQFP	5.5	C	PQ
512K x 18	GS880F18BGT-6.5V	Flow Through	1.8 V or 2.5 V	RoHS-compliant TQFP	6.5	C	PQ
512K x 18	GS880F18BGT-7.5V	Flow Through	1.8 V or 2.5 V	RoHS-compliant TQFP	7.5	C	PQ
256K x 32	GS880F32BGT-5.5V	Flow Through	1.8 V or 2.5 V	RoHS-compliant TQFP	5.5	C	PQ
256K x 32	GS880F32BGT-6.5V	Flow Through	1.8 V or 2.5 V	RoHS-compliant TQFP	6.5	C	PQ
256K x 32	GS880F32BGT-7.5V	Flow Through	1.8 V or 2.5 V	RoHS-compliant TQFP	7.5	C	PQ
256K x 36	GS880F36BGT-5.5V	Flow Through	1.8 V or 2.5 V	RoHS-compliant TQFP	5.5	C	PQ
256K x 36	GS880F36BGT-6.5V	Flow Through	1.8 V or 2.5 V	RoHS-compliant TQFP	6.5	C	PQ
256K x 36	GS880F36BGT-7.5V	Flow Through	1.8 V or 2.5 V	RoHS-compliant TQFP	7.5	C	PQ
512K x 18	GS880F18BGT-5.5IV	Flow Through	1.8 V or 2.5 V	RoHS-compliant TQFP	5.5	I	PQ
512K x 18	GS880F18BGT-6.5IV	Flow Through	1.8 V or 2.5 V	RoHS-compliant TQFP	6.5	I	PQ

**Notes:**

- Customers requiring delivery in Tape and Reel should add the character "T" to the end of the part number. Example: GS880F18BT-5.5IVT.
- The speed column indicates the cycle frequency (MHz) of the device in Pipeline mode and the latency (ns) in Flow Through mode. Each device is Pipeline/Flow through mode-selectable by the user.
- T<sub>A</sub> = C = Commercial Temperature Range. T<sub>A</sub> = I = Industrial Temperature Range.
- MP = Mass Production. PQ = Pre-Qualification.
- GSI offers other versions of this type of device in many different configurations and with a variety of different features, only some of which are covered in this data sheet. See the GSI Technology web site ([www.gsistechnology.com](http://www.gsistechnology.com)) for a complete listing of current offerings.

**Ordering Information for GSI Synchronous Burst RAMs**

Org	Part Number <sup>1</sup>	Type	Voltage Option	Package	Speed <sup>2</sup> (ns)	T <sub>A</sub> <sup>3</sup>	Status <sup>4</sup>
512K x 18	GS880F18BGT-7.5IV	Flow Through	1.8 V or 2.5 V	RoHS-compliant TQFP	7.5	I	PQ
256K x 32	GS880F32BGT-5.5IV	Flow Through	1.8 V or 2.5 V	RoHS-compliant TQFP	5.5	I	PQ
256K x 32	GS880F32BGT-6.5IV	Flow Through	1.8 V or 2.5 V	RoHS-compliant TQFP	6.5	I	PQ
256K x 32	GS880F32BGT-7.5IV	Flow Through	1.8 V or 2.5 V	RoHS-compliant TQFP	7.5	I	PQ
256K x 36	GS880F36BGT-5.5IV	Flow Through	1.8 V or 2.5 V	RoHS-compliant TQFP	5.5	I	PQ
256K x 36	GS880F36BGT-6.5IV	Flow Through	1.8 V or 2.5 V	RoHS-compliant TQFP	6.5	I	PQ
256K x 36	GS880F36BGT-7.5IV	Flow Through	1.8 V or 2.5 V	RoHS-compliant TQFP	7.5	I	PQ

**Notes:**

- Customers requiring delivery in Tape and Reel should add the character "T" to the end of the part number. Example: GS880F18BT-5.5IVT.
- The speed column indicates the cycle frequency (MHz) of the device in Pipeline mode and the latency (ns) in Flow Through mode. Each device is Pipeline/Flow through mode-selectable by the user.
- T<sub>A</sub> = C = Commercial Temperature Range. T<sub>A</sub> = I = Industrial Temperature Range.
- MP = Mass Production. PQ = Pre-Qualification.
- GSI offers other versions this type of device in many different configurations and with a variety of different features, only some of which are covered in this data sheet. See the GSI Technology web site ([www.gsitechnology.com](http://www.gsitechnology.com)) for a complete listing of current offerings.

Not Recommended for New Design

## 9Mb Sync SRAM Datasheet Revision History

DS/Date Rev. Code: Old; New	Types of Changes Format or Content	Page;Revisions;Reason
880FxxB_V_r1		• Creation of new datasheet
880FxxB_V_r1; 880FxxB_V_r1.01	Content	• Updated Truth Tables

**Not Recommended for New Design**